



US009915136B2

(12) **United States Patent**
Eisaman et al.

(10) **Patent No.:** **US 9,915,136 B2**
(45) **Date of Patent:** **Mar. 13, 2018**

(54) **HYDROCARBON EXTRACTION THROUGH CARBON DIOXIDE PRODUCTION AND INJECTION INTO A HYDROCARBON WELL**

4,392,959 A	7/1983	Coillet
6,905,606 B1	6/2005	Kikuyama et al.
7,117,106 B2	10/2006	Rusta-Sallehy et al.
7,198,722 B2	4/2007	Hussain
7,655,193 B1	2/2010	Rau et al.
7,700,214 B1	4/2010	Iyer et al.
7,790,012 B2*	9/2010	Kirk B01D 53/326 204/263
7,906,028 B2	3/2011	Constantz et al.
7,931,809 B2	4/2011	Constantz et al.
7,947,239 B2	5/2011	Lackner et al.
8,227,127 B2	7/2012	Little et al.

(Continued)

(71) Applicant: **X Development LLC**, Mountain View, CA (US)

(72) Inventors: **Matthew D. Eisaman**, Port Jefferson, NY (US); **Kathleen E. Cooper**, Palo Alto, CA (US)

(73) Assignee: **X Development LLC**, Mountain View, CA (US)

(*) Notice: Subject to any disclaimer, the term of this patent is extended or adjusted under 35 U.S.C. 154(b) by 0 days.

FOREIGN PATENT DOCUMENTS

CN	102936067 A	2/2013
EP	1276795	3/2006

(Continued)

(21) Appl. No.: **15/165,311**

(22) Filed: **May 26, 2016**

(65) **Prior Publication Data**

US 2017/0342813 A1 Nov. 30, 2017

(51) **Int. Cl.**
E21B 43/16 (2006.01)
C25B 7/00 (2006.01)

(52) **U.S. Cl.**
CPC **E21B 43/164** (2013.01); **C25B 7/00** (2013.01)

(58) **Field of Classification Search**
CPC E21B 43/164; C05B 7/00
USPC 166/305.1
See application file for complete search history.

(56) **References Cited**

U.S. PATENT DOCUMENTS

3,075,828 A	1/1963	Kato et al.
4,036,749 A	7/1977	Anderson

OTHER PUBLICATIONS

Eisaman M. D. et al., CO2 separation using bipolar membrane electrodialysis, Energy & Environmental Science, Apr. 2011, 10 pages.

(Continued)

Primary Examiner — Silvana C Runyan

(74) Attorney, Agent, or Firm — Christensen O'Connor Johnson Kindness PLLC

(57) **ABSTRACT**

A method of extracting hydrocarbons from a hydrocarbon well includes receiving an aqueous solution including dissolved inorganic carbon, and extracting the dissolved inorganic carbon from the aqueous solution to create CO₂ by changing a pH of the aqueous solution. The method also includes pumping the CO₂ into the hydrocarbon well and, in response to pumping the CO₂ into the hydrocarbon well, extracting the hydrocarbons from the hydrocarbon well.

16 Claims, 4 Drawing Sheets

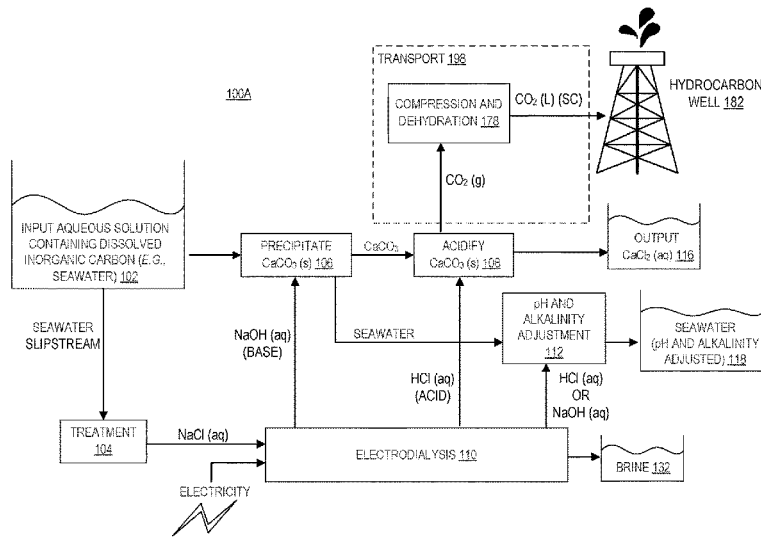

(56)

References Cited

U.S. PATENT DOCUMENTS

8,313,557 B2 11/2012 Willauer et al.
 8,337,589 B2 12/2012 Wright et al.
 8,685,250 B2 4/2014 Choi et al.
 8,778,156 B2 7/2014 Eisaman et al.
 8,784,632 B2 7/2014 Eisaman et al.
 8,936,700 B2 1/2015 Newman et al.
 8,999,171 B2 4/2015 Wallace
 9,227,168 B1 1/2016 DeVaul et al.
 2005/0074657 A1 4/2005 Rusta-Sallehy et al.
 2008/0031801 A1 2/2008 Lackner et al.
 2008/0033338 A1 2/2008 Smith
 2008/0093307 A1 4/2008 Somers et al.
 2009/0001020 A1 1/2009 Constantz et al.
 2010/0028242 A1 2/2010 Willauer et al.
 2010/0233767 A1 9/2010 McMurrin
 2010/0288700 A1 11/2010 Lahav et al.
 2011/0056876 A1 3/2011 Ide et al.
 2011/0135551 A1 6/2011 House et al.
 2011/0174507 A1 7/2011 Burnham et al.
 2011/0177550 A1 7/2011 McMurrin
 2011/0224578 A1 9/2011 Edman et al.
 2011/0226006 A1 9/2011 Lackner et al.
 2011/0237839 A1 9/2011 Waldstein
 2011/0281959 A1 11/2011 DiMascio et al.
 2012/0211421 A1 8/2012 Self et al.
 2012/0220019 A1 8/2012 Lackner
 2012/0244053 A1 9/2012 Self et al.
 2013/0008792 A1 1/2013 Eisaman et al.
 2013/0034760 A1 2/2013 Otts et al.
 2013/0036748 A1 2/2013 Lewis
 2013/0206605 A1 8/2013 DiMascio et al.
 2013/0281553 A1 10/2013 Kubic et al.
 2013/0343981 A1 12/2013 Wright et al.
 2014/0002788 A1 1/2014 Otts et al.
 2014/0217024 A1 8/2014 Monzyk et al.
 2014/0234735 A1 8/2014 Zhang et al.
 2014/0238869 A1 8/2014 DiMascio et al.
 2014/0272639 A1 9/2014 Zietlow
 2014/0303452 A1 10/2014 Ghaffari
 2014/0322803 A1 10/2014 Constantz et al.
 2014/0338903 A1 11/2014 Mahmoud et al.
 2015/0246314 A1* 9/2015 Constantz B01D 53/62
 423/220
 2015/0274536 A1 10/2015 Wright et al.
 2015/0298806 A1 10/2015 Lind et al.
 2016/0082387 A1 3/2016 Constantz et al.

FOREIGN PATENT DOCUMENTS

EP 2074066 7/2009
 EP 2465600 6/2012
 EP 2465601 6/2012
 EP 2543427 1/2013
 WO WO 9412465 6/1994
 WO WO 2010/142943 A2 12/2010
 WO WO 2011/090376 A1 7/2011

OTHER PUBLICATIONS

U.S. Appl. No. 14/971,122—Electrodialytic CO₂ Purification and Stripping, filed Dec. 16, 2015, 16 pages
 U.S. Appl. No. 14/736,847—Energy Efficient Method for Stripping CO₂ From Seawater, filed Jun. 11, 2015, 16 pages.
 U.S. Appl. No. 14/750,800—CO₂ Sequestration Via Desalination, filed Jun. 25, 2015, 16 pages.
 Willauer, H. D. et al., Extraction of Carbon Dioxide from Seawater by an Electrochemical Acidification Cell. Part 2 —Laboratory Scaling Studies, Apr. 2011, 22 pages.
 Eisaman M. D. et al., CO₂ extraction from seawater using bipolar membrane electrodialysis, May 2012, 8 pages.
 Biorock International Coral Reef Restoration, Biorock International Corporation, 2012, 2 pages.
 Rangel C. M. et al., Integrating hydrogen generation and storage in a novel compact electrochemical system based on metal hydrides, Jul. 2008, 5 pages.
 U.S. Appl. No. 62/342,061—Method for Efficient CO₂ Degasification, filed May 26, 2016, 23 pages.
 U.S. Appl. No. 15/165,867—Method for Feeding Algae Using Reclaimed CO₂, filed May 26, 2016, 19 pages.
 U.S. Appl. No. 15/165,885—Metal Hydride Electrolysis System, filed May 26, 2016, 21 pages.
 U.S. Appl. No. 62/342,065—Chemical Extraction From an Aqueous Solution, filed May 26, 2016, 29 pages.
 U.S. Appl. No. 15/165,205—Chemical Extraction From an Aqueous Solution and Power Generator Cooling, filed May 26, 2016, 30 pages.
 U.S. Appl. No. 15/165,260—Building Materials From an Aqueous Solution, filed May 26, 2016, 29 pages.
 U.S. Appl. No. 15/165,357—Fuel Synthesis From an Aqueous Solution, filed May 26, 2016, 31 pages.
 International Application No. PCT/US2017/032217—International Search Report and Written Opinion dated Aug. 10, 2017, 15 pages.

* cited by examiner

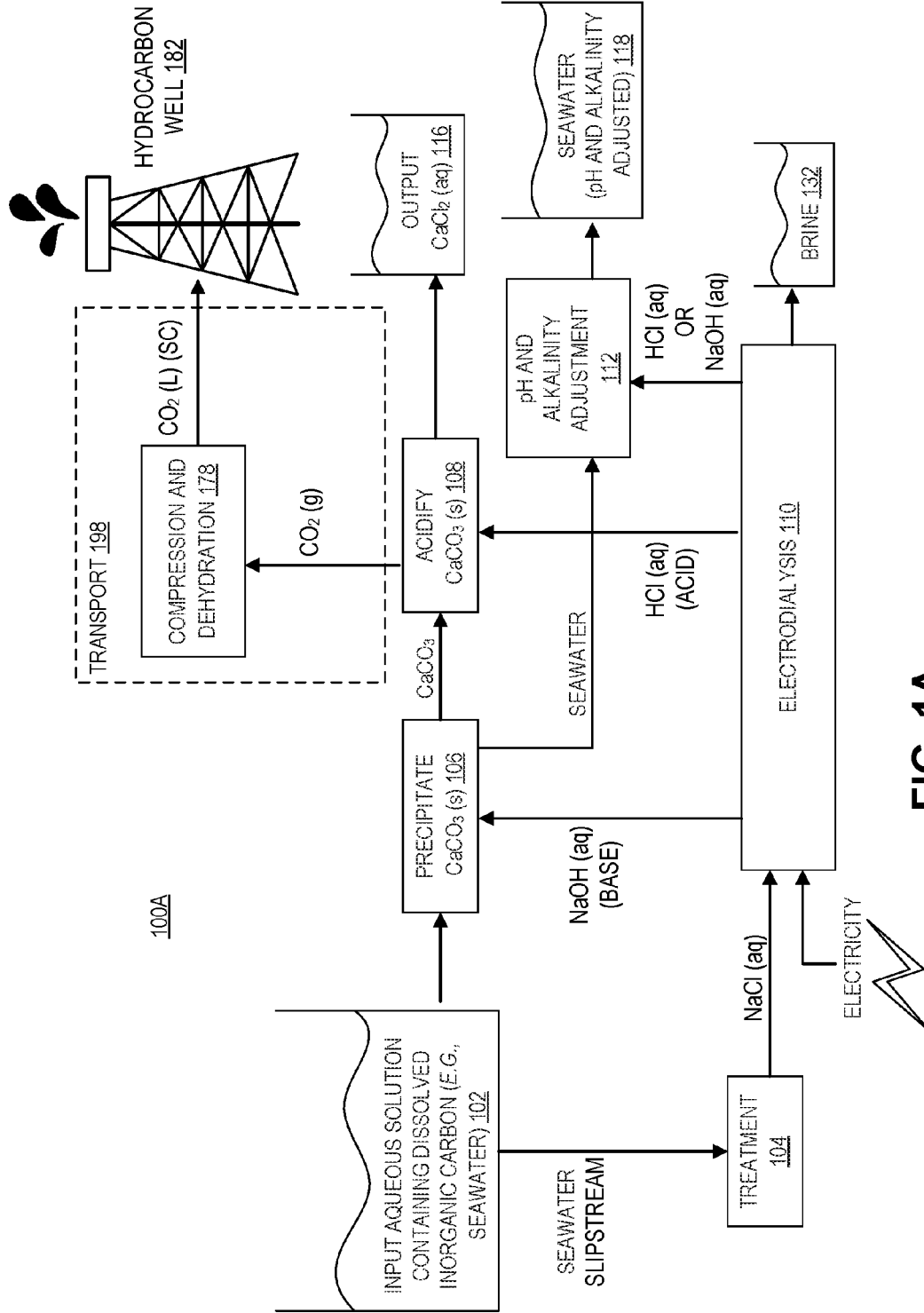

FIG. 1A

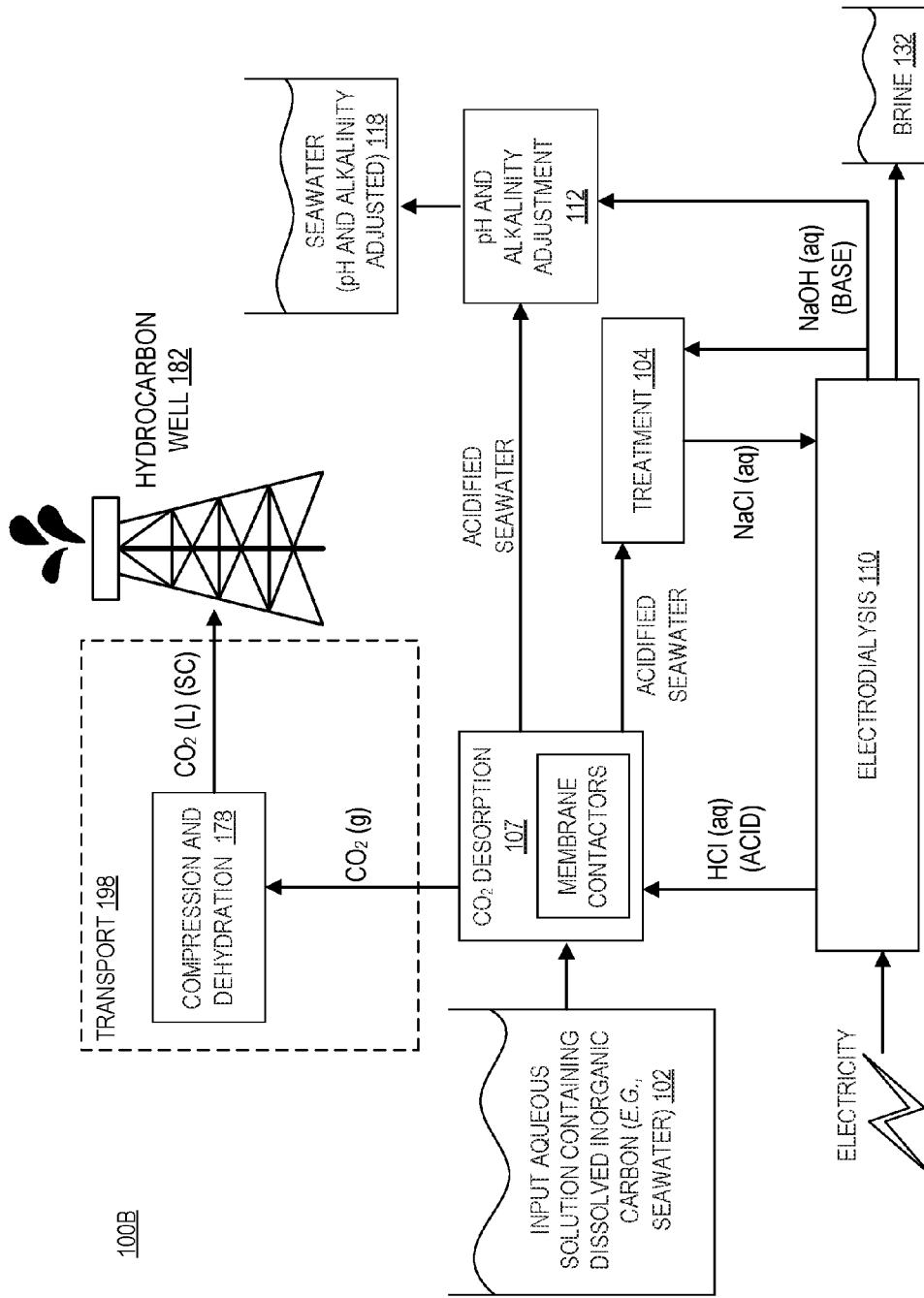

FIG. 1B

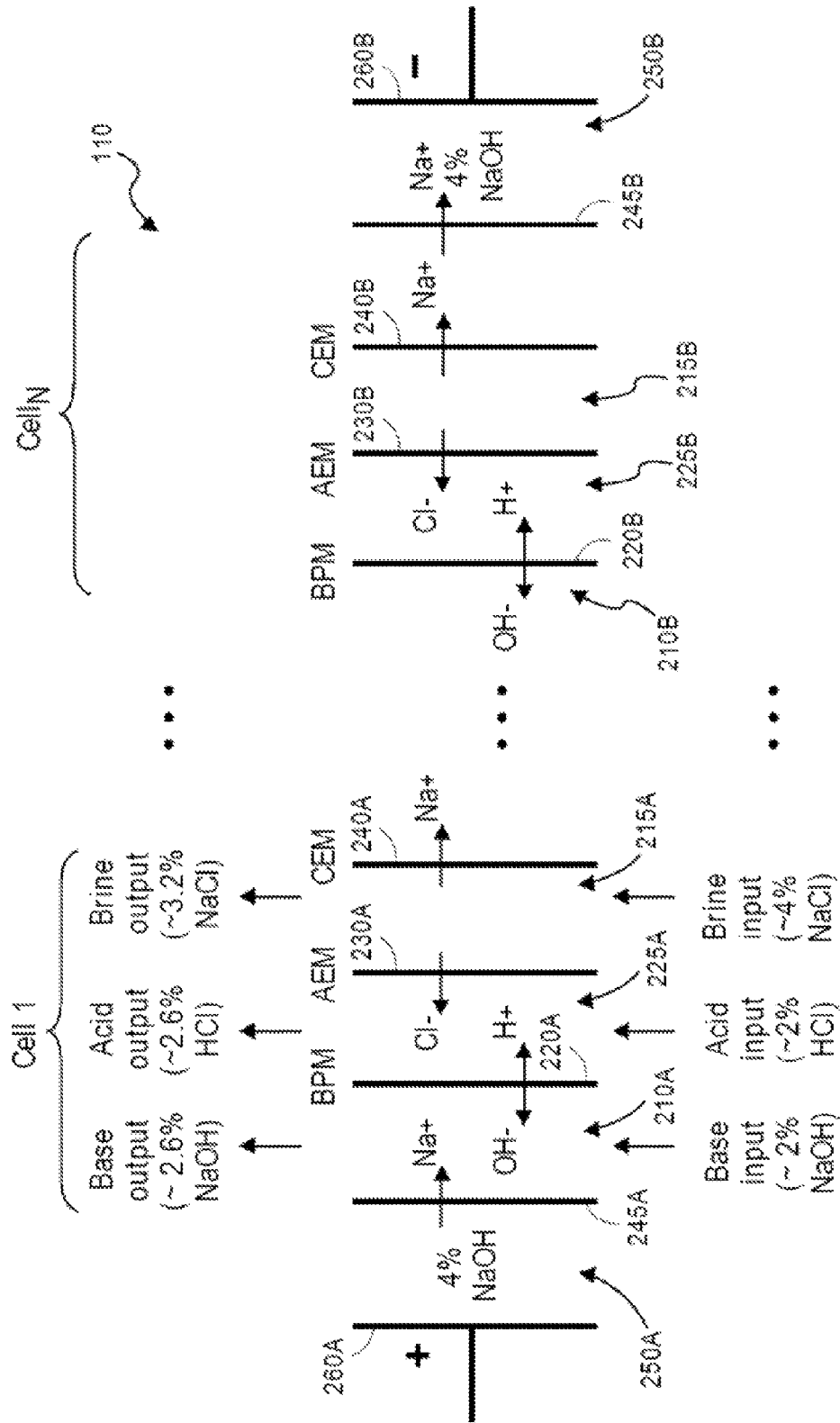

FIG. 2

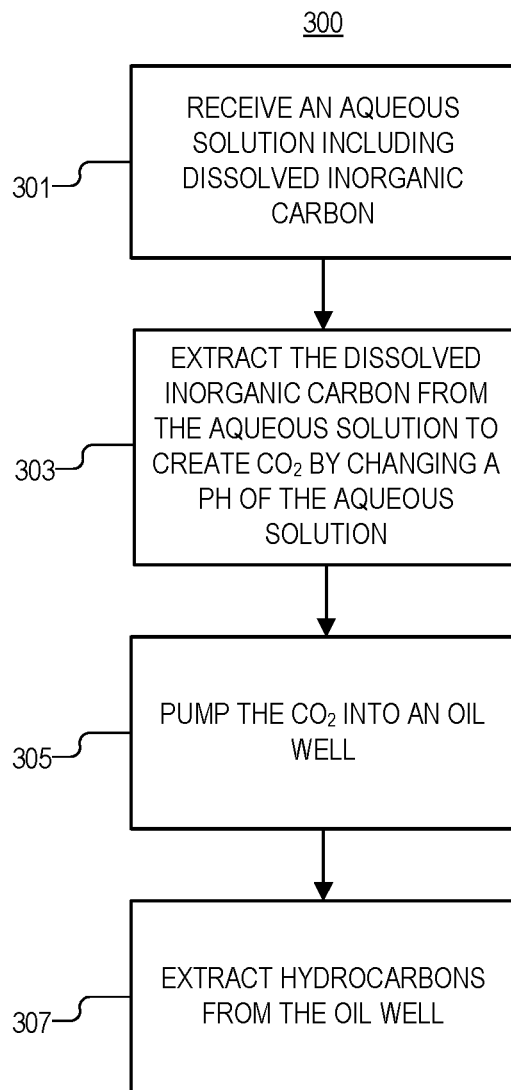

FIG. 3

HYDROCARBON EXTRACTION THROUGH CARBON DIOXIDE PRODUCTION AND INJECTION INTO A HYDROCARBON WELL

TECHNICAL FIELD

This disclosure relates generally to hydrocarbon extraction.

BACKGROUND INFORMATION

Pure carbon dioxide (CO₂) has many industrial uses. The separation of CO₂ from a mixed-gas source may be accomplished by a capture and regeneration process. More specifically, the process generally includes a selective capture of CO₂, by, for example, contacting a mixed-gas source with a solid or liquid adsorber/absorber followed by a generation or desorption of CO₂ from the adsorber/absorber. One technique describes the use of bipolar membrane electrodialysis for CO₂ extraction/removal from potassium carbonate and bicarbonate solutions.

For capture/regeneration systems, a volume of gas that is processed is generally inversely related to a concentration of CO₂ in the mixed-gas source, adding significant challenges to the separation of CO₂ from dilute sources such as the atmosphere. CO₂ in the atmosphere, however, establishes equilibrium with the total dissolved inorganic carbon in the oceans, which is largely in the form of bicarbonate ions (HCO₃⁻) at an ocean pH of 8.1-8.3. Therefore, a method for extracting CO₂ from the dissolved inorganic carbon of the oceans would effectively enable the separation of CO₂ from atmosphere without the need to process large volumes of air.

BRIEF DESCRIPTION OF THE DRAWINGS

Non-limiting and non-exhaustive embodiments of the invention are described with reference to the following figures, wherein like reference numerals refer to like parts throughout the various views unless otherwise specified. The drawings are not necessarily to scale, emphasis instead being placed upon illustrating the principles being described.

FIG. 1A is an illustration of a system for extracting hydrocarbons from a hydrocarbon well, in accordance with an embodiment of the disclosure.

FIG. 1B is an illustration of a system for extracting hydrocarbons from a hydrocarbon well, in accordance with an embodiment of the disclosure.

FIG. 2 is an example electrodialysis unit, in accordance with an embodiment of the disclosure.

FIG. 3 is an illustration of a method for extracting hydrocarbons from a hydrocarbon well, in accordance with an embodiment of the disclosure.

DETAILED DESCRIPTION

Embodiments of an apparatus and method for enhanced hydrocarbon extraction are described herein. In the following description numerous specific details are set forth to provide a thorough understanding of the embodiments. One skilled in the relevant art will recognize, however, that the techniques described herein can be practiced without one or more of the specific details, or with other methods, components, materials, etc. In other instances, well-known structures, materials, or operations are not shown or described in detail to avoid obscuring certain aspects.

Reference throughout this specification to “one embodiment” or “an embodiment” means that a particular feature, structure, or characteristic described in connection with the embodiment is included in at least one embodiment of the present invention. Thus, the appearances of the phrases “in one embodiment” or “in an embodiment” in various places throughout this specification are not necessarily all referring to the same embodiment. Furthermore, the particular features, structures, or characteristics may be combined in any suitable manner in one or more embodiments.

Throughout the specification and claims, compounds/elements are referred to both by their chemical name (e.g., carbon dioxide) and chemical symbol (e.g., CO₂). It is appreciated that both chemical names and symbols may be used interchangeably and have the same meaning.

This disclosure provides for the removal of carbon from water sources containing dissolved inorganic carbon (e.g., bicarbonate ions HCO₃⁻), converting the dissolved carbon into dissolved CO₂ gas, stripping the CO₂ gas from the water source, and using the CO₂ to extract oil or natural gas from hydrocarbon wells. Enhanced oil recovery (EOR) is a method for extracting additional fossil fuel from an existing well by injecting CO₂ into the well to displace and eject hydrocarbons. The economic potential for EOR in nearshore and offshore wells is enormous. Using CO₂ extracted from the ocean to remove hydrocarbons from existing oil wells may be more environmentally friendly than drilling a new well. CO₂ from the ocean is sequestered in the existing well to help offset the hydrocarbons extracted. In addition, the alkalinity of the decarbonized seawater is restored by addition of NaOH prior to returning the water to the ocean, resulting in reabsorption of CO₂ from the atmosphere into the parcel of returned water. Further, there is no need to drill a new well, limiting further environmental damage and reducing the chance of drilling accidents.

FIG. 1A is an illustration of system 100A for extracting hydrocarbons from hydrocarbon well 182, in accordance with an embodiment of the disclosure. System 100A includes: input 102 (to input an aqueous solution containing dissolved inorganic carbon), treatment unit 104, precipitation unit 106, acidification unit 108, electrodialysis unit 110, pH and alkalinity adjustment unit 112, CaCl₂ output 116, water output 118, brine output 132, transport system 198 (including compression and dehydration unit 178), and hydrocarbon well 182.

As shown, input 102 is coupled to a water reservoir containing dissolved inorganic carbon (e.g., bicarbonate ions). The water reservoir may be an ocean, lake, river, manmade reservoir, or brine outflow from a reverse osmosis (“RO”) process. Input 102 may receive the water through a system of channels, pipes, and/or pumps depending on the specific design of the facility. As shown, water received through input 102 is diverted into two separate sections of system 100A. A first (smaller) portion of the water is diverted to treatment unit 104, while a second (larger) portion of the water is diverted to precipitation unit 106. One skilled in the art will appreciate that large aggregate may be removed from the water at any time during the intake process.

In the illustrated embodiment, the first portion of water is diverted into treatment unit 104. Treatment unit 104 outputs a relatively pure stream of aqueous NaCl. In other words, an aqueous solution (possibly including seawater) is input to treatment unit 104, and aqueous NaCl is output from treatment unit 104. Treatment unit 104 may be used to remove organic compounds and other minerals (other than NaCl) not needed in, or harmful to, subsequent processing steps. For

example, removal of chemicals in the water may mitigate scale buildup in electro dialysis unit **110**. Treatment unit **104** may include filtering systems such as: nanofilters, RO units, ion exchange resins, precipitation units, microfilters, screen filters, disk filters, media filters, sand filters, cloth filters, and biological filters (such as algae scrubbers), or the like. Additionally, treatment unit **104** may include chemical filters to removed dissolved minerals/ions. One skilled in the art will appreciate that any number of screening and/or filtering methods may be used by treatment unit **104** to remove materials, chemicals, aggregate, biologicals, or the like.

Electro dialysis unit **110** is coupled to receive aqueous NaCl and electricity, and output aqueous HCl, aqueous NaOH, and brine (to brine output **132**). Aqueous HCl and aqueous NaOH output from electro dialysis unit **110** may be used to drive chemical reactions in system **100A**. The specific design and internal geometry of electro dialysis unit **110** is discussed in greater detail in connection with FIG. **2** (see infra FIG. **2**). Brine output from electro dialysis unit **110** may be used in any applicable portion of system **100A**. For example, brine may be cycled back into electro dialysis unit **110** as a source of aqueous NaCl, or may be simply expelled from system **100A** as wastewater.

In the illustrated embodiment, precipitation unit **106** has a first input coupled to receive an aqueous solution including dissolved inorganic carbon (e.g., seawater) from input **102**. Precipitation unit **106** also has a second input coupled to electro dialysis unit **110** to receive aqueous NaOH. In response to receiving the aqueous solution and the aqueous NaOH, precipitation unit **106** precipitates calcium salts (for example, but not limited to, CaCO₃) and outputs the aqueous solution. However, in other embodiments, other chemical processes may be used to basify the aqueous solution in precipitation unit **106**. For example, other bases (not derived from the input aqueous solution) may be added to the aqueous solution to precipitate calcium salts.

In one embodiment, NaOH is added to incoming seawater until the pH is sufficiently high to allow precipitation of calcium salts without significant precipitation of Mg(OH)₂. The exact pH when precipitation of CaCO₃ occurs (without significant precipitation of Mg(OH)₂) will depend on the properties of the incoming seawater (alkalinity, temperature, composition, etc.); however, a pH of 9.3 is typical of seawater at a temperature of 25° C. In a different embodiment, the quantity of NaOH added is sufficient to precipitate CaCO₃ and Mg(OH)₂, then the pH is lowered (e.g., by adding HCl from electro dialysis unit **110** until the pH is <9.3) so that the Mg(OH)₂ (but not CaCO₃) redissolves.

In one embodiment, precipitation unit **106** may be a large vat or tank. In other embodiments precipitation unit **106** may include a series of ponds/pools. In this embodiment, precipitation of calcium salts may occur via evaporation driven concentration (for example using solar ponds) rather than, or in combination with, adding basic substances. Precipitation unit **106** may contain internal structures with a high surface area to promote nucleation of CaCO₃; these high surface area structures may be removed from the precipitation unit **106** to collect nucleated CaCO₃. Precipitation unit **106** may include an interior with CaCO₃ to increase nucleation kinetics by supplying seed crystals. The bottom of precipitation unit **106** may be designed to continually collect and extract precipitate to prevent large quantities of scale buildup.

In another or the same embodiment, heat may be used to aid precipitation. For example solar ponds may be used to heat basified water. In continuously flowing systems, low temperature waste heat solution may be flowed through heat

exchange tubes with basified seawater on the outside of the tubes. Alternatively, heating the bottom of precipitation unit **106** may be used to speed up precipitation.

After CaCO₃ is precipitated from the water, CaCO₃ is transferred to acidification unit **108**. In the depicted embodiment, acidification unit **108** is coupled to receive CaCO₃ from precipitation unit **106** and coupled to receive aqueous HCl from electro dialysis unit **110**. In response to receiving CaCO₃ and aqueous HCl, acidification unit **108** produces CO₂. In the depicted embodiment, acidification unit **108** is used to evolve CaCO₃ into CO₂ gas and aqueous CaCl₂ according to the following reaction: CaCO₃ (s)+2HCl (aq) →CaCl₂ (aq)+H₂O (l)+CO₂ (g). Reaction kinetics may be increased by agitating/heating the acidified mixture. By adding HCl to CaCO₃, CO₂ is spontaneously released due to the high equilibrium partial pressure of CO₂ gas. This may eliminate the need for membrane contactors or vacuum systems.

Acidification unit **108** is coupled to transport system **198**. In the depicted embodiment transport system **198** may be a system of pipes, pumps, chambers, and/or gas cylinders coupled directly between acidification unit **108** and hydrocarbon well **182**. However, in other embodiments, transport system **198** may not be directly coupled. In other words, the CO₂ extracted from acidification unit **108** may be contained in compress gas cylinders or the like, which are transported to hydrocarbon well **182** to displace the hydrocarbons (e.g., oil and natural gas) from hydrocarbon well **182**. However, for purposes of this disclosure it may be said that transport system **198** is “coupled” to both acidification unit **108** and hydrocarbon well **182** even when the CO₂ is contained in chambers and trucked to hydrocarbon well **182** for hydrocarbon extraction. Discontinuity in the transport process is contemplated by the claims in the instant application.

In one embodiment, transport system **198** may alter the temperature or the pressure of the CO₂ prior to or after transport, so the CO₂ is denser than the gas phase of CO₂ when the CO₂ enters hydrocarbon well **182**. To accomplish this, transport system **198** may include compression and dehydration unit **178** to remove water from the CO₂ and to change a phase of the CO₂ into at least one of a liquid or a supercritical fluid.

CO₂ used in EOR is of a purity >95%, and the temperature and pressure of the CO₂ is adjusted to ensure that the CO₂ is in a denser phase than the gas phase of CO₂ (either liquid or supercritical)—for CO₂, a supercritical fluid occurs at temperatures greater than 31.1° C., and pressures greater than 7.38 MPa. One noteworthy advantage of system **100A** is that producing CO₂ from CaCO₃ eliminates the need for N₂O₂ degassing steps; the CO₂ extracted by addition of HCl to CaCO₃(s) can be sent directly to compression and dehydration unit **178** to produce the >95% purity liquid or supercritical CO₂ appropriate for EOR.

Once all CO₂ has been extracted from acidification unit **108**, wastewater containing CaCl₂ is output from system **100A** via CaCl₂ output **116**. In one embodiment, the wastewater is returned to the ocean or other water source after the pH of the wastewater has been adjusted. In other embodiments, the wastewater is sequestered in hydrocarbon well **182** and used as part of the EOR process (water injection).

In the depicted embodiment, the second portion of seawater (that was used as a carbon source in precipitation unit **106**) is flowed to a pH and alkalinity adjustment unit **112**. The pH and alkalinity adjustment unit **112** is coupled to electro dialysis unit **110** to receive HCl and NaOH, and adjust a pH and alkalinity of the combined second portion of the aqueous solution and basic solution to a pH and alka-

linity of seawater (or other environmentally safe pH value). In one embodiment, the pH and alkalinity of wastewater flowed into pH and alkalinity adjustment unit **112** is monitored in real time, and HCl or NaOH is flowed into pH and alkalinity adjustment unit **112** in response to the real time measurements. Adjusting the pH of wastewater flowing from system **100A** ensures minimal environmental impact of running system **100A**, while adjusting the alkalinity ensures sufficient reabsorption of atmospheric CO₂ once the water is returned to the ocean.

FIG. 1B is an illustration of system **100B** for extracting hydrocarbons from hydrocarbon well **182**, in accordance with an embodiment of the disclosure. System **100B** is similar in many respects to system **100A** of FIG. 1A. However, one major difference is system **100B** has degasification unit **107**, in lieu of precipitation unit **106** and acidification unit **108**.

In the depicted embodiment, electro dialysis unit **110** is coupled to receive aqueous NaCl, and to output aqueous HCl and aqueous NaOH. Degasification unit **107** has a first input coupled to receive an aqueous solution including dissolved inorganic carbon, and a second input coupled to electro dialysis unit **110** to receive the aqueous HCl. In response to receiving the aqueous solution and the aqueous HCl, degasification unit **107** evolves CO₂ from the aqueous solution and outputs the aqueous solution. As shown, the aqueous solution may include seawater, and the aqueous NaCl may also be derived, at least in part, from seawater. Degasification unit **107** may include membrane contactors to remove dissolved N₂ and O₂ gas from the aqueous solution, prior to evolving the CO₂ from the aqueous solution. This results in >95% purity CO₂ at the outset of the degasification and dehydration process. It is worth noting that in other embodiments, other gases may be extracted from the aqueous solution. Furthermore, any of the processes described above may be vacuum assisted.

Transport system **198** is coupled to degasification unit **107** to transport the CO₂ from degasification unit **107** into hydrocarbon well **182** (to displace the hydrocarbons in hydrocarbon well **182**). In one embodiment, the transport system **198** alters at least one of a temperature or a pressure of the CO₂ either before or after transport so the CO₂ is denser than the gas phase of CO₂ when the CO₂ enters hydrocarbon well **182**. In the depicted embodiment, transport system **198** includes compression and dehydration unit **178** to remove water from the CO₂ and to change a phase of the CO₂ into at least one of a liquid or a supercritical fluid.

Systems **100A-100B** may be coupled to, and run by, electronic control systems. Regulation and monitoring may be accomplished by a number of sensors throughout the system that either send signals to a controller or are queried by controller. For example, with reference to electro dialysis unit **110**, monitors may include one or more pH gauges to monitor a pH within the units as well as pressure sensors to monitor a pressure among the compartments in electro dialysis unit **110** (to avoid inadvertent mechanical damage to electro dialysis unit **110**). Another monitor may be a pH gauge placed within precipitation unit **106** to monitor a pH within the tank. The signals from such pH monitor or monitors allows a controller to control a flow of brine solution (from input **102**) and a basified solution (from electro dialysis unit **110**) to maintain a pH value of a combined solution that will result in a precipitation of CaCO₃.

Alternatively, systems **100A-100B** may be controlled manually. For example, a worker may open and close valves to control the various water, acid, and base flows in systems **100A-100B**. Additionally, a worker may remove precipi-

tated calcium salts from precipitation unit **106**. However, one skilled in the relevant art will appreciate that systems **100A-100B** may be controlled by a combination of manual labor and mechanical automation, in accordance with the teachings of the present disclosure.

FIG. 2 is an example electro dialysis unit **110** (e.g., electro dialysis unit **110** of FIG. 1A-1B), in accordance with an embodiment of the disclosure. Electro dialysis unit **110** may be used to convert seawater (or other NaCl-containing aqueous solutions) into NaOH and HCl. As shown, in FIGS. 1A-1B, NaOH and HCl may be used to adjust the pH of the aqueous solution to precipitate calcium salts and evolve CO₂ gas. In one embodiment electro dialysis unit **110** is a bipolar membrane electro dialysis unit.

In the depicted embodiment, electro dialysis unit **110** representatively consists of several cells in series, with each cell including a basified solution compartment (compartments **210A** and **210B** illustrated); an acidified solution compartment (compartments **225A** and **225B** illustrated); and a brine solution compartment (compartments **215A** and **215B**). FIG. 2 also shows a bipolar membrane (BPM) between a basified solution compartment and an acidified solution compartment (BPM **220A** and **220B** illustrated). A suitable BPM is a Neosepta BP-1E, commercially available from Ameridia Corp. Also depicted are anion exchange membranes (AEM), such as Neosepta ACS (commercially available from Ameridia Corp.), disposed between a brine compartment and an acidified solution compartment (AEM **230A** and **230B** illustrated). A cation exchange membrane (CEM) such as Neosepta CMX-S (commercially available from Ameridia Corp.), is disposed adjacent to a brine compartment (CEM **240A** and CEM **240B** illustrated). Finally, FIG. 2 shows end cap membranes **245A** and **245B** (such as Nafion® membranes) that separate the membrane stack from electrode solution compartment **250A** and electrode solution compartment **250B**, respectively.

Broadly speaking, under an applied voltage provided to electro dialysis unit **110**, water dissociation inside the BPM (and the ion-selective membranes comprising a BPM) will result in the transport of hydrogen ions (H⁺) from one side of the BPM, and hydroxyl ions (OH⁻) from the opposite side. AEMs/CEMs, as their names suggest, allow the transport of negatively/positively charged ions through the membrane. The properties of these membranes such as electrical resistance, burst strength, and thickness are provided by the manufacturer (e.g., Neosepta ACS and CMX-S are monovalent-anion and monovalent-cation permselective membranes, respectively). In one embodiment, electro dialysis unit **110** includes electrodes **260A** and **260B** of, for example, nickel manufactured by De Nora Tech Inc. FIG. 2 also shows electrode solution compartment **250A** and electrode solution compartment **250B** through which, in one embodiment, a NaOH(aq) solution is flowed. Where electrode **260A** is a positively-charged electrode, sodium ions (Na⁺) will be encouraged to move across cap membrane **245A** and where electrode **260B** is negatively-charged, sodium ions will be attracted to electrode solution compartment **250B**. In one embodiment, the solution compartments between adjacent membranes are filled with polyethylene mesh spacers (e.g., 762 μm thick polyethylene mesh spacers), and these compartments are sealed against leaks using axial pressure and 794 mm thick EPDM rubber gaskets.

FIG. 3 is a flow chart illustrating a method **300** for extracting hydrocarbons from a hydrocarbon (oil and/or natural gas) well, in accordance with an embodiment of the disclosure. The order in which some or all of process blocks **301-307** appear in method **300** should not be deemed

limiting. Rather, one of ordinary skill in the art having the benefit of the present disclosure will understand that some of method **300** may be executed in a variety of orders not illustrated, or even in parallel. Additionally, method **300** may include additional blocks or have fewer blocks than shown, in accordance with the teachings of the present disclosure.

Block **301** illustrates receiving an aqueous solution including dissolved inorganic carbon. In one embodiment, the aqueous solution includes seawater containing bicarbonate ions (HCO_3^-).

Block **303** discloses extracting the dissolved inorganic carbon from the aqueous solution to create CO_2 by changing a pH of the aqueous solution. In one embodiment this may include increasing the pH of the aqueous solution to precipitate salts containing carbon, and applying acid to the salts to evolve CO_2 gas. This process may include adding aqueous NaOH to the aqueous solution (to increase the pH), and applying HCl to the salts (to evolve the CO_2). In an alternate embodiment, extracting the dissolved inorganic carbon includes decreasing the pH of the aqueous solution to remove CO_2 gas from the aqueous solution. In this embodiment, decreasing the pH includes adding aqueous HCl to the aqueous solution, and the aqueous HCl is produced by an electro dialysis unit. Further, N_2 and O_2 may be removed from the aqueous solution before decreasing the pH of the aqueous solution.

Block **305** shows pumping the CO_2 into the hydrocarbon well. In one embodiment, the density of the CO_2 may be altered to be greater than the density of CO_2 gas by adjusting the temperature or and/or pressure. Thus, the CO_2 pumped into the well may be a liquid or a supercritical fluid of greater than 95% purity.

Block **307** illustrates extracting the hydrocarbons from the hydrocarbon well, in response to pumping CO_2 into the well. The CO_2 may mix with and/or displace hydrocarbons (e.g., oil or natural gas) in the well, resulting in their migration towards the surface. CO_2 injection into a hydrocarbon well is a miscible displacement process. A miscible displacement process may maintain pressure in the well and improve oil displacement due to reduced interfacial tension between oil and water in the well. Carbon dioxide may be best suited for miscible displacement because it reduces oil viscosity, and may be less expensive than other gases.

In the case of CO_2 EOR, the first step includes injecting water into the well. In one embodiment this may include wastewater from the CO_2 extraction process. Once the reservoir is pressurized with water, CO_2 is pumped down into the well. The CO_2 gas then comes in contact with the oil. The oil- CO_2 contact area creates a miscible zone that is easily moved/extracted. In some instances, oil field workers may alternate between injection of CO_2 and water, because water helps sweep oil towards the production area. Method **300** disclosed here may be used for producing CO_2 in places where there is ample seawater but no CO_2 supply chain. Thus, method **300** may enable the recovery of millions of barrels of otherwise inaccessible oil.

The above description of illustrated embodiments of the invention, including what is described in the Abstract, is not intended to be exhaustive or to limit the invention to the precise forms disclosed. While specific embodiments of, and examples for, the invention are described herein for illustrative purposes, various modifications are possible within the scope of the invention, as those skilled in the relevant art will recognize.

These modifications can be made to the invention in light of the above detailed description. The terms used in the following claims should not be construed to limit the inven-

tion to the specific embodiments disclosed in the specification. Rather, the scope of the invention is to be determined entirely by the following claims, which are to be construed in accordance with established doctrines of claim interpretation.

What is claimed is:

1. A method of extracting hydrocarbons from a hydrocarbon well, comprising:

receiving an aqueous solution including dissolved inorganic carbon with a carbon extraction unit;

extracting the dissolved inorganic carbon from the aqueous solution to create CO_2 by changing a pH of the aqueous solution, wherein changing the pH includes receiving, with the carbon extraction unit, aqueous NaOH or aqueous HCl from an electro dialysis unit coupled to the carbon extraction unit;

pumping the aqueous solution from the carbon extraction unit into the hydrocarbon well after extracting the dissolved inorganic carbon from the aqueous solution;

pumping the CO_2 into the hydrocarbon well; and

in response to pumping the CO_2 into the hydrocarbon well, extracting the hydrocarbons from the hydrocarbon well.

2. The method of claim 1, wherein extracting the dissolved inorganic carbon includes:

increasing the pH of the aqueous solution to precipitate salts containing carbon; and

applying acid to the salts to evolve CO_2 gas.

3. The method of claim 2, wherein increasing the pH includes adding aqueous NaOH to the aqueous solution, and wherein applying the acid to the salts includes applying aqueous HCl to the salts.

4. The method of claim 1, wherein extracting the dissolved inorganic carbon includes decreasing the pH of the aqueous solution to remove CO_2 gas from the aqueous solution.

5. The method of claim 4, wherein decreasing the pH includes adding aqueous HCl to the aqueous solution, wherein the aqueous HCl is produced by an electro dialysis unit.

6. The method of claim 5, further comprising removing N_2 and O_2 from the aqueous solution before decreasing the pH of the aqueous solution.

7. The method of claim 1, further comprising:

receiving the CO_2 from the carbon extraction unit with a compression and dehydration unit coupled to the carbon extraction unit; and

altering the density of the CO_2 with the compression and dehydration unit to be greater than a density of CO_2 gas by adjusting at least one of a temperature or a pressure.

8. The method of claim 7, wherein pumping the CO_2 into the hydrocarbon well includes outputting the CO_2 from the compression and dehydration unit into the hydrocarbon well, wherein the compression and dehydration unit is coupled to the hydrocarbon well, and the CO_2 pumped into the hydrocarbon well is at least one of a liquid or a supercritical fluid.

9. The method of claim 1, wherein the CO_2 is greater than 95% pure.

10. The method of claim 1, further comprising filtering the aqueous solution, including sea water, with a treatment unit coupled to the electro dialysis unit to remove ions and organic matter from the sea water.

11. The method of claim 1, wherein the electro dialysis unit is coupled to perform operations comprising:

receiving the aqueous solution with a brine solution compartment disposed in the electro dialysis unit;

9

applying a voltage across electrodes in the electro dialysis unit;

outputting the aqueous solution from the brine solution compartment with a lower salt concentration in response to the voltage applied across the electrodes;

receiving the aqueous HCl with an acidified solution compartment disposed in the electro dialysis unit; applying the voltage across the electrodes in the electro dialysis unit; and

outputting the aqueous HCl, with a higher HCl concentration, from the acidified solution compartment, wherein chlorine ions in the brine solution compartment traveled to the acidified solution compartment in response to the voltage across the electrodes.

12. The method of claim **11**, wherein the electro dialysis unit is coupled to perform operations further comprising:

receiving the aqueous NaOH with a basified compartment disposed in the electro dialysis unit;

applying the voltage across the electrodes in the electro dialysis unit; and outputting the aqueous NaOH from the basified solution compartment with a higher NaOH concentration in response to the voltage applied across the electrodes.

13. The method of claim **12**, wherein in response to the voltage, the chlorine ions flow through an anion exchange

10

membrane disposed between the brine solution compartment and the acidified solution compartment, and wherein in response to the voltage, hydrogen ions and hydroxyl ions flow through a bipolar membrane disposed between the acidified solution compartment and the basified solution compartment.

14. The method of claim **13**, wherein applying the voltage across the electrodes in the electro dialysis unit includes collecting sodium ions at a negatively charged terminal, and wherein the brine solution compartment, the acidified solution compartment, and the basified solution compartment are included in a first cell in a plurality of cells in the electro dialysis unit.

15. The method of claim **14**, further comprising neutralizing the aqueous solution, in a pH and alkalinity adjustment unit coupled to the electro dialysis unit, with the aqueous NaOH or the aqueous HCl, after extracting the dissolved inorganic carbon from the aqueous solution.

16. The method of claim **8**, further comprising directly outputting the CO₂ from the compression and dehydration unit into the hydrocarbon well without degassing O₂ gas or N₂ gas from the CO₂.

* * * * *